

Particulate Matter 10 Microns

PM 10

Wedding Samplers

**2.5 PROCEDURES FOR AMBIENT AIR MONITORING FOR PM10
(40CFR50 - APPENDIX J)**

Revision 4 is a complete document. There are no current revisions for Wedding samplers prior to 4. For Anderson samplers use revision 3.

<u>Section</u>	<u>Date</u>	<u>Revision</u>
2.5.1 CALIBRATION AND MAINTENANCE	10/01/01	4
2.5.1.1 Rootsmeter - Standard		
2.5.1.2 Orifice Calibration Unit / Audit Device		
2.5.1.3 Calibration of Hi- Volume Samplers		
2.5.1.3.1 Volumetric Flow Controllers		
2.5.1.4 Elapsed Time Indicator		
2.5.1.5 Balance Room Parameters		
2.5.1.6 Analytical Balance		
2.5.1.7 Audit Device		
2.5.1.8 Barometer		
2.5.1.9 Thermometer		
2.5.2 MONITORING PROCEDURES	10/01/01	4
2.5.2.1 Preparation for the Field		
2.5.2.2 Sample Collection		
2.5.2.3 Filter Installation and Set up		
2.5.2.4 Documentation		
2.5.3 LABORATORY PROCEDURES	10/01/01	4
2.5.3.0 PM10 Filters		
2.5.3.1 Documentation		
2.5.4 DATA HANDLING PROCEDURES	10/01/01	4
2.5.4.1 Data Preparation		
2.5.4.2 Data Submittal		
2.5.5 QUALITY ASSURANCE PROCEDURES	10/01/01	4
2.5.5.1 Procedures for the Operator		
2.5.5.2 Procedures for the Auditor		
2.5.5.3 Procedures for the Headquarters' Staff		

**APPENDIX M CHAIN OF CUSTODY PROCEDURES FOR PARTICULATE
ENFORCEMENT SAMPLES (O4/01/97)**

2.5 PARTICULATE MATTER 10 MICRONS (PM10) USING VOLUMETRIC FLOW CONTROLLERS

2.5.0.1 The Electronic Calibration Branch shall procure air monitoring equipment and appurtenances for the Division of Air Quality and maintain an inventory of spare parts and supplies. Spare parts and assistance should be requested on the AQ-109.

2.5.1 MAINTENANCE AND CALIBRATION

2.5.1.1 ROOTSMETER - STANDARD

- (1) Maintenance, Check and service annually
- (2) Calibration, Refer to Section 2.3.2.1 Rootsmeter

2.5.1.2 ORIFICE CALIBRATION UNIT / AUDIT DEVICE

- (1) Maintenance, Inspect annually during calibration
- (2) Calibration, Refer to Section 2.3.2.2 Orifice Calibration Unit and Reference Flow Device

2.5.1.3 PM10 HIGH VOLUME SAMPLERS

2.5.1.3.1 PM 10 Sampler with a Critical Flow Device (CFD)-General Description.

EACH CFD UNIT is identified by a number (it has its own corresponding "Look-up" chart specific to that CFD). In volumetric flow controllers, the air through a choked-flow venturi attains sonic velocity and is unaffected by motor speed in excess of the critical speed, exit pressure, filter funnel stagnation pressure and temperature. Thus, the volumetric flow is without moving parts and has **no** means for adjusting the controlled flow rate. The sampler calibration, using the Orifice Calibration Unit [utilizing the PM10 slope(m) and intercept(b)], verifies the accuracy of the critical venturi by comparing the known orifice calibration unit flow rate against a factory calibration flow rate listed on the

"Look-up" chart. The flow rates should agree within $\pm 4.0\%$. The actual flow rate of the sampler during operation must be $40 \text{ ft}^3/\text{min}$ ($1.13 \text{ M}^3/\text{min}$) $\pm 10\%$ ($36\text{-}44 \text{ ft}^3/\text{min}$). The CFD is designed for a proper operating flow rate over a broad range of temperature and pressure conditions.

2.5.1.3.2. Maintenance for Wedding PM10 Sampler with Critical Flow Device (CFD). Maintenance consists primarily of inspection, the repair of physical damage, and the periodic replacement of motor brushes, motors, and switches. The equipment must be inspected frequently for damage or wear (frayed / cut cord; loose, cracked, or leaking gaskets or leaking strain relief.) See Figure 2.5.1.3.2. Any defective parts must be repaired or replaced before a calibration is performed. Make sure the correct replacement motors (Amtec-Lamb 923) and brushes BMW B-4) are installed during maintenance. The preferred method of brush replacement is to install and burn in the brushes on extra motors at the office/shop (see procedure 2.5.1.3.2.1). Then replace the motor in the field after the ending calibration. Once the motor is installed, a beginning calibration must be performed. Calibrations may be affected by line voltage (ie below 110 volts). Periodically check the Line voltage at the site and always calibrate the sampler at the site.

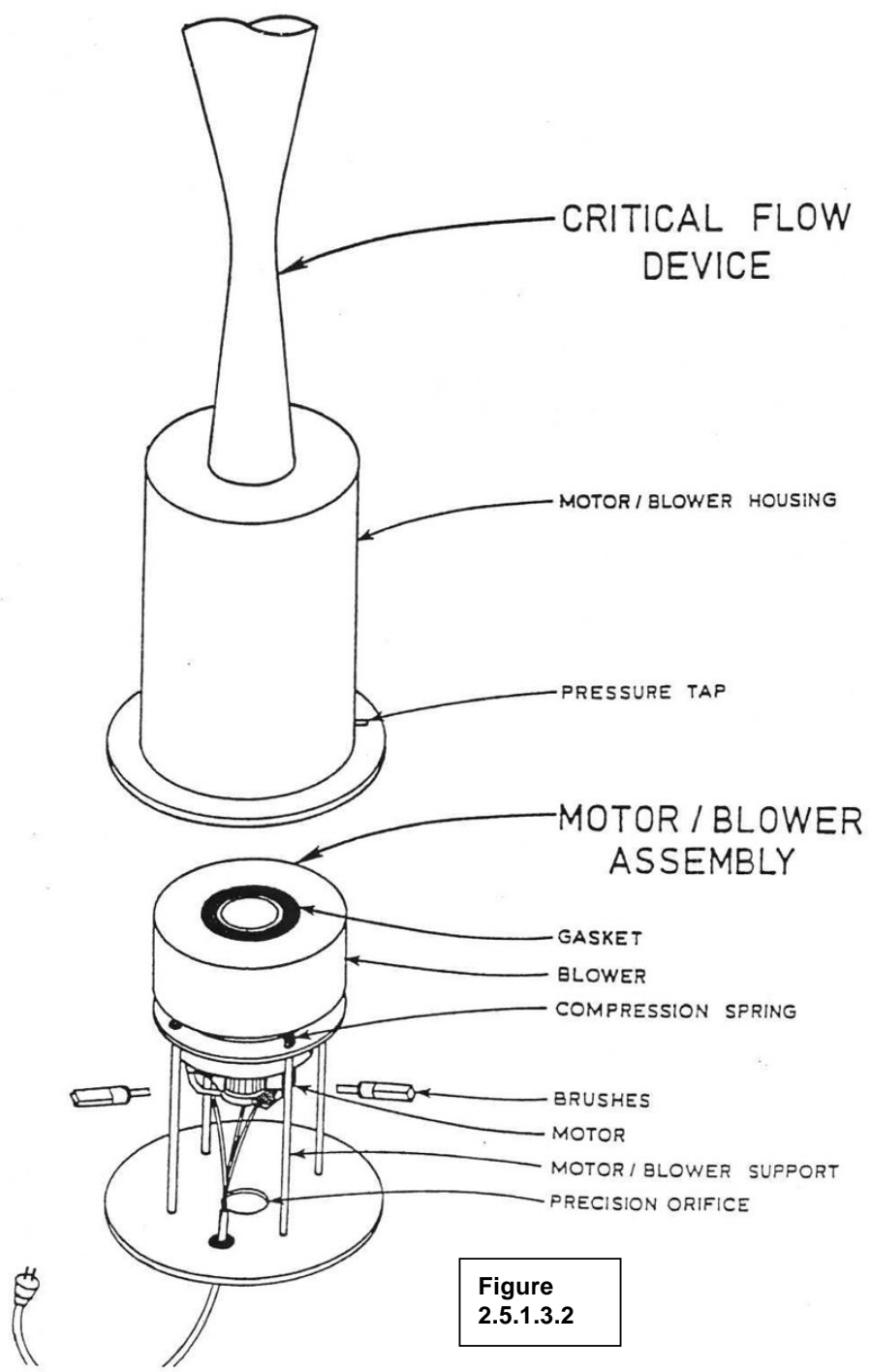

Figure
2.5.1.3.2

2.5.1.3.2.1 BRUSH REPLACEMENT PROCEDURE

The brushes/motor must be replaced after approximately 360 hours of operation or no longer than 91 days. The brushes may be replaced sooner if an inspection or performance warrants. A small work area and the following items are needed for brush replacement:

Brush set	Soft cloth	Short handled phillips screwdriver
Crocus cloth	AC Power	Common screwdriver, jeweler size
Solvent, (isopropyl alcohol)		

- (a) Disconnect the sampler from electricity
- (b) Loosen the two (2) plastic pronged knobs in the upper rear corners of the shelter and tilt the VFC to permit access/removal of the motor assembly.
- (c) Remove the four(4) knobs that attach the motor housing to the bottom of the VFC. Slide out the motor assembly.
- (d) Place the motor assembly, brush end up, on the work surface.
- (e) Examine the brush assembly. Note the arrangement and clamping method and how the brush is attached to the connector. Also notice the position locator on the bottom of the brush. Compare the new brush to the one in the motor to verify the same type of brush.
- (f) At one brush, remove the 2 clamp screws. Remove the clamp. Grasp the outer end of the brush assembly and lift up slightly allowing the brush to push itself away from the commutator.
- (g) While holding the brush assembly in this position, dislodge the connector (push away from the brush assembly) using a jeweler's common screwdriver. Allow the brush assembly to move away from the commutator slightly, which will give the connector clearance from the commutator. Exercise care moving the connector as the wire may break.
- (h) After the brush assembly has been removed, examine the commutator. (Use your finger or a ratchet to rotate the armature from the air input end.

- (i) Never use a tool at the commutator to rotate the armature.) If it is scored, it should be lightly polished with a crocus cloth. If pitted, use a pumice stone to smooth the commutator. If the commutator is smooth but blackened, clean with a cloth dipped in cleaning solvent and air dry.
- (i) Place the new brush assembly in the same position as item g. Install the connector by pushing it into the brush at the point at which it was originally removed. Check to see that the wires to the brushes do not touch the metal of the motor frame.
- (j) Reseat the brush against the commutator. When the brush is properly oriented, replace the clamp and partially tighten the screws. Move the brush to insure that it is properly seated. Tighten the screws.
- (k) Follow the preceding instructions to remove and replace the second brush assembly.
- (l) Reconnect the wire nuts that attach the power cord to the motor at the sampler.
- (m) Slide the motor assembly into the housing and replace the four (4) knobs.
- (n) Return the VFC to the operating position. Replace the two (2) black plastic pronged knobs up inside the upper rear corners of the sampler housing.
- (o) Brush burn-in or seating should be accomplished at the office. If seating has been accomplished, connect the power cord to the sampler power outlet. Brush seating at the office, follow this procedure:
 - 1. Attach the ECB supplied Y-cord or stand (2 power) to the "burn-in" motor, a second motor (preferably another burn-in motor), and a standard wall outlet (115vAC) power source.
 - 2. Run the motor at 2 power for thirty minutes and allow to cool.
Remove the Y-cord.
 - 3. Plug into a power supply(115vAC), run for thirty minutes at full power (no Y-cord), and allow the motor to cool. The brush seating is complete.

2.5.1.3.2.2 Cleaning the Wedding PM10 Inlet

The Wedding PM10 Inlet should be cleaned after every fifteen (15) sampling days or once every three (3) months. The Wedding Inlet for the High-Volume Sampler is constructed such that the site of the primary deposition is readily accessible for cleaning through the Maintenance Access Port (Figure 2.5.1.3.2.2). To reach the Maintenance Access Port located on the top of the Wedding PM10 Inlet either utilize a step ladder or disengage the safety catches and fold the sampler down at the rear hinge being careful not to let the full weight of the sampler head “hang” without support. The latter approach requires removal of both the Left and Right Safety Catch Brackets. Once the Brackets are removed, lower the Inlet for access to the Port. **Always gently lower the head to the support so as not to bend the metal head on impact.** To clean the Inlet, remove the four (4) plastic-pronged knobs located on the plate on top of the inlet. Remove the Maintenance Access Port to expose the fractionating assembly (vanes). Pass the supplied cleaning brush down the inner tube, rotating it as it is pushed up and down, to remove the collected particles for a total of at least (3) “round trips” through the tube. Should any residual particle material remain on any surface, it should be removed by blowing or wiping. The oiled deposition surface is continually regenerated by the internal oil reservoir. **No re-oiling of the surface is required by the user.** When maintenance is completed, replace the Maintenance Access Port, ensure gasket seals and tighten the four (4) plastic knobs in place. Lift the head into sampling position, reinstall the left and right safety catches, and reinstall base plate knobs.

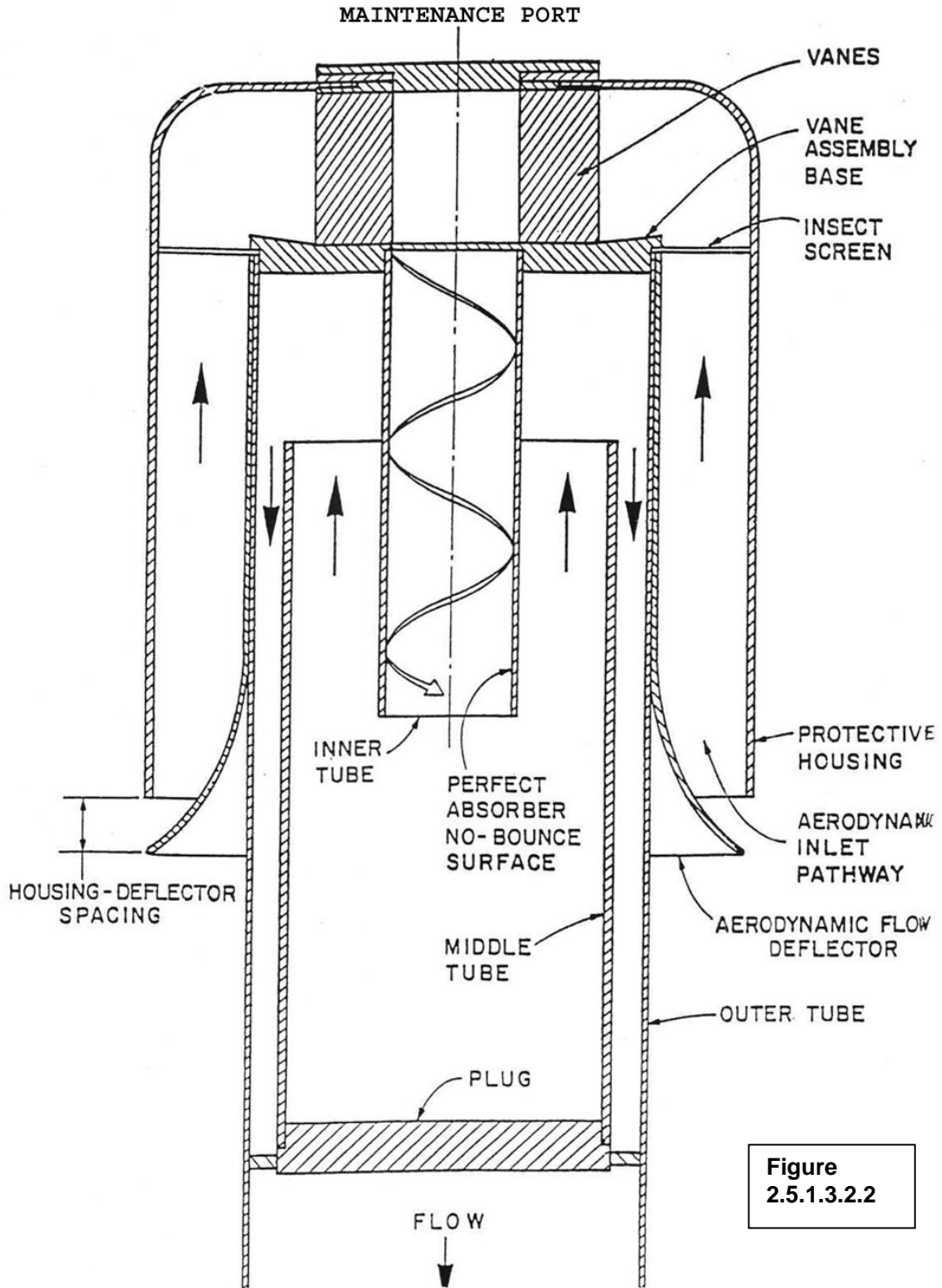

Figure
2.5.1.3.2.2

2.5.1.3.2.3 WEDDING SEAL CHANGE PROCEDURE

1. Perform an ending calibration of the sampler.
2. Remove the brackets that limit the rearward travel of the PM10 head.
3. Remove the screws that attach the rear hinges to the bottom of the sampler.
4. Remove the screws from the 3 brackets that secure the base (filter rest) of the sampler.
5. Lift the PM10 head away from the sampler. Set it down so that it rests in its normal vertical position on the ground.

NOTE: All seals and all glue must be completely removed prior to applying the new seal. Seal is removed with scraper and solvent. For glue removal suggest "goo gone" and Simple Green in concert.

Head section

1. Remove the four (4) winged finger locknuts.
2. Remove the cover plate, remove and replace (R&R) the seal (3.5"OD) on the bottom of the cover plate.
3. Remove the next plate secured with four (4) phillips screws (be careful not to drop the screws down the particle separator shaft). R&R the 4.25"OD gasket (top side of plate).
4. R&R the vane gasket seal, 5"OD (bottom side of plate).
5. Clean vanes (small brush) and particle shaft (larger "toilet" brush) at this time for required quarterly cleaning.
6. Reassemble in reverse order.

Base Section

1. R&R both the 17"x 17" and the 9"x 11" gaskets on the top plate of the base.
2. R&R the three (3) 9"x 11" seals on the filter cartridge.
3. Remove the motor assembly from the CFD. R&R the motor end seal, this seal must be changed more frequently than every 3 years.
4. **DO NOT ATTEMPT TO REMOVE THE SEAL BETWEEN THE BOTTOM OF THE SCREEN AND THE CFD.**
5. Reassemble in reverse order.

2.5.1.3.2.4 Calibration

Calibration is required upon installation, before and after maintenance, when moved to new location, and after every 360 hours/15 sample runs. **Do not exceed 91 days between calibrations.**

2.5.1.3.2.4.1 Calibration Procedure

The volumetric flow-controlled sampler will be calibrated at one point near the design flowrate of (40 acfm). Periodic calibrations every 3 months (less than 91 days) are required to establish accuracy and consistency.

Calibration equipment:

Orifice Transfer Standard (traceable to NIST).

2 Manometers (4+4" H₂O to 0.1 inch) and (12+12" H₂O to 0.1 inch)/or

electronic manometers verified by ECB

Thermometer [certified in degrees Centigrade converted to K]

Barometer, certified, read to nearest mm Hg

Quartz filter

(a) Upon arrival at the site allow equilibration of an NIST certified thermometer, record the ambient temperature (T_a) and ambient pressure (P_a) on the PM10 e-log calibration sheet (Figure 2.5.1.3.2.4.1).

PM 10 SAMPLER CALIBRATION

SITE NAME	AIRS NUMBER		DATE	QUARTER	OPERATOR		
Lex	370570002		1/31/01	1	CB		
ORIFICE #	ORIFICE CERT DATE		m		b		
			0.1838		-0.4975		
P_a	T_a	T_K	P_{avg}		T_{avg}		
731.00	14.0	287.00	739.73		6.71		
ϵH (in H ₂ O)	ϵP_f (in H ₂ O)	ϵP_f (mm Hg)	P_o/P_a	Q_a (acfm)	Q_a (orifice)	% Diff	
Filter							
5.0	21.0	39.27	0.946	40.10	41.1251	-2.4926	
End Cal	5.1	21.2	39.64	0.946	40.10	41.5074	-3.3906
Begin Cal							
% Diff should be less than 4%. If not investigate, correct, and reaccomplish below.							
Q_a (orifice) This value must be 40 acfm +/- 4 acfm. If not reaccomplish below.							
If still > +/- 4 acfm call ECB.							
Comments				Don't overwrite red cells			
				Only fill/write in yellow cells			
region notes							

Figure 2.5.1.3.2.4.1

(b) Install the calibration orifice and a Quartz filter on the sampler. Turn on the sampler and check for leaks by blocking all open ports. **WARNING: DO NOT CONNECT THE MANOMETER TO THE CALIBRATION ORIFICE (ΔH) UNTIL THIS LEAK TEST IS COMPLETED.** Do not run the leak check more than 30 seconds. Listen for any whistling sound that may indicate faulty gaskets or cross threading. Ensure that the filter screen is properly aligned with the top loading adapter. If not, adjust the screen forward and backward until the gasket seals the top of the filter screen correctly. If the unit still leaks, retighten or realign and retest until leaks are found.

(c) Zero the manometers being used.

Water manometers are adjusted to zero by:

1. insuring the vents for each side are open (turned counterclockwise)

2. loosening the retaining device and sliding the scale so that both sides of the U-tube are zeroed at the bottom of the water minuscus, retighten the retaining device

Electronic Manometers:

1. Turn on (push the **on** button)
2. Zero (twist set knob on top, without being attached to the sampler)

(d) Connect one side of the large manometer to the stagnation port pressure tap located on the side of the sampler housing (ϵP_f), see figure 2.5.5.2.1.1.1, and leave the other side open to the atmosphere. (The quick connect located on the station housing closes automatically when the manometer is disconnected.) Connect the orifice to the small manometer. Insure the electronic manometer is "on" before connecting to any port. **CAUTION: If the electronic manometer is "OFF" when connected, damage to the diaphragm may result.**)

(e) Turn on the sampler motor. Insure it is allowed to warmup for 5 minutes.

(f) While waiting, record on the calibration data sheet: date, location, operator, sampler motor number, CFD S/N, orifice S/N and the orifice PM-10 calibration slope and intercept.

(g) After 5 minutes, record the funnel pressure (ϵP_f) and the orifice pressure (ϵH).

(h) Convert the ϵP_f (inches H_2O) to mm Hg using this formula:

mm Hg = 1.87 x inches H_2O , Record on calibration form.

(i) Calculate the CFD pressure ratio P_o/P_a :

$$P_o/P_a = \frac{(P_a - P_f)}{P_a}$$

where P_a = ambient pressure, and P_f = CFD pressure (both in mm Hg)

- (j) Determine the calibration orifice flow rate, Q_a (ACFM):

$$Q_a = \frac{((\Delta H \times 25.4 \times T_a/P_a)^2) - b}{m} \quad \text{Note: } (x)^2 = \text{Square root } x = \sqrt{x}$$

Where T_a = ambient temperature ° Kelvin = ° Centigrade + 273

P_a = ambient pressure in mm Hg

m and b are the slope and intercept for the orifice.

- (k) Determine the expected flow rate for the funnel, Q_f . Go to the Look-up table for the CFD and use the temperature in ° F = ((° C x9/5) + 32) and the pressure ratio P_o/P_a to determine the CFD expected flow rate.

Interpolation may be required for the actual temperature.

- (l) Determine the percent difference:

$$\text{Percent difference} = \frac{Q_f - Q_a}{Q_a} \times 100$$

The Percent difference between the Orifice flow rate (Q_a) & the expected look up flow rate (Q_f) must agree within $\pm 4\%$. If the percent difference is $\leq 4\%$, the calibration is considered validated.

- (m) **If the % difference is > 4%, troubleshoot the calculations & the sampler:**

Recheck the orifice transfer constants and calculations of the calibration procedure. Check for manometer reading errors and incorrect

temperature or pressure data. Make sure the serial numbers for the hardware and the lookup tables match. Recheck the system for leaks. Inspect the CFD for debris or corrosion in the throat. If necessary clean with soap and water. If still not within $\pm 4\%$, check that the line voltage is ≥ 110 v AC. Inspect the blower motor, check for adequate brushes and gaskets. If necessary, change existing motor and brushes and recalibrate.

(n) If all efforts to calibrate fail, return the sampler to the Electronics and Calibration Branch (ECB) for replacement.

2.5.1.4 ELAPSED TIME INDICATOR (ETI)

Verify at least annually. (Section 2.3.2.4). The ETI accuracy is important since the final calculated pollutant concentrations are dependant on the sample time. The ETI must be accurate within ± 2 minutes in 24 hours.

2.5.1.5 BALANCE ROOM PARAMETERS

- (1) The temperature must be kept at $22^{\circ}\text{C} \pm 2^{\circ}\text{C}$.
- (2) The relative humidity must be kept at $38\% \text{ rel} \pm 5\% \text{ rel}$.

2.5.1.6 ANALYTICAL BALANCE

- (1) The balance must be serviced annually. Record servicing in the logbook and obtain a certificate from the servicing company.
- (2) Perform a one point check with standard weight before each use. Record the actual and the measured weights in the lab logbook.
- (3) Perform a full scale check quarterly with "S" class weights. Record these balance checks in the lab database.

2.5.1.7 AUDIT DEVICE

Calibrate annually. Refer to Section 2.3.2.3 for procedures, except use the audit designated orifice in place of the orifice calibration unit.

2.5.1.8 BAROMETER

Aneroid - Certify semi-annually by ECB according to Section 2.3.3.3.

Electronic - Verify annually

2.5.1.9 THERMOMETER

Mercury - Certify annually by ECB according to Section 2.3.3.4.

Electronic - Verify annually

2.5.2 MONITORING PROCEDURES

2.5.2.1 PREPARATION FOR THE FIELD

2.5.2.1.1 Use quartz filters only for PM10 sampling. Always ensure the quartz filters are installed in the filter cartridge rough side up and number side down. Before carrying the filters into the field, complete the AQ-41 (see form in Appendix M) to reflect sampling station and projected date of sampling. If the sampler is involved in an enforcement case, "chain of custody" procedures must be utilized. All individuals handling the filter from initial weighing at the lab, to the operator, and locations of storage must be documented on this form to include the time the filter is in the sampler. This chain continues through final weighing and storage at the lab. All signatures utilize the AQ-41 for documentation. The complete chain of custody procedures are located in appendix M of the Air Quality Monitoring Quality Assurance Plan.

2.5.2.1.2 Paper clip the AQ-41's to individual zip lock style bags with the filter in it marked according to the sampling route.

2.5.2.2 SAMPLE COLLECTION (REMOVING EXPOSED FILTER FROM THE PM10 MONITOR)

2.5.2.2.1 Connect the pressure reading device to the pressure tap on the outside of the PM10 housing(ΔP_f). The recorder is not calibrated, it is used to measure changes in flow and indicate problems only.

2.5.2.2.2 Move the 7-day timer switch to the "on" position and allow high volume sampler to operate for 5 full minutes. At the end of the 5 minute warm-up period and after the air flow rate has stabilized, read the manometer to the nearest one tenth scale

division. Record the pressure reading. Convert the ΔP_f (inches H₂O) to mm Hg using this formula: mm Hg = 1.87 x inches H₂O. Use this value to calculate the final stagnation pressure P_{ff} (36-44 acfm) according to the Look-up table. (see step 2.5.1.3.2.4,1 item # k). If the reading is not in the acceptable range, perform the recalibration maintenance in 2.5.1.3.2.4.1 item # m and calibrate under section 2.5.1.3.2.4. If the readings are still not in the acceptable range, replace the motor and recalibrate. If this fails, return the CFD unit to the ECB for recertification/maintenance. Obtain a replacement if available.

2.5.2.2.3 Move the 7-day timer switch to the "off" position, disconnect the manometer and read the elapsed time indicator to the nearest 0.1 minute and then record on the AQ-41 data sheet. The total sample time must be 1380 to 1500 min. If not, the sample is invalidated. Readjust / troubleshoot the sampler / timer if total sample time is not between 1380-1500 min.

2.5.2.2.4 Check the recorder readings for flow. It is not calibrated. The chart recorder is used to indicate if there were major flow changes (± 4 CFM) and to verify that the sampler ran uninterrupted. If interrupted, check the monitoring system to identify the cause.

2.5.2.2.5 Remove the used filter as follows:

- (a) Raise the sampler PM10 Inlet (head) by removing six knobs and gently tilting back the inlet until the safety catch can be locked into position.
- (b) Remove the filter cartridge by loosening and removing the four corner knobs from the filter cartridge.
- (c) Check that the gasket is in good condition and has not deteriorated. Examine the filter support screen and if it appears dirty, wipe it clean.
- (d) Remove the filter and note any unusual conditions which may affect the samples, date and initial the AQ-41.

- (e) Fold the filter so that the particulate-coated surfaces are in contact and that the resulting folded filter is 8" x 5". Place the folded filter into a zip lock bag and then into the folded corresponding AQ-41. Remove the labeled recorder chart and place the recorder chart in the folded corresponding AQ-41.
- (f) At the office, store the filter until ready for shipping in a sealed, labeled file case.
- (g) Note any unusual conditions which may affect samples, date, and initial AQ-41. Place the filter, chart, and AQ-41 in the manila envelope, then lock the shipping container after placing each sample in the container.
- (h) Return the shipping container to the regional office after completing the sampling route. Filters and associated paperwork must be reviewed by the Regional Office Auditor. The filters should then be shipped every second week to the Lab. Do not delay either the pick-up from the sampler or the shipment to Lab. The regional office should not have any filters that are more than 1 week old since having been sampled.

2.5.2.2.6.1 AQ-41 processing. The e-log book automatically performs the following calculations. The following demonstrates these calculations.

- (a) Record the appropriate T_s and P_s , seasonal average temperature and pressure, on the AQ-41.
- (b) Calculate the average stagnation pressure (P_{fa}) in mm Hg as:

$$P_{fa} = \frac{\text{initial stag. Pressure}(P_{fi}) + \text{final stag. Pressure}(P_{ff})}{2}$$

- (c) Calculate the Pressure Ratio P_o/P_s as:

$$P_o/P_s = \frac{P_s - P_{fa}}{P_s}$$

where: P_s = seasonal geographic average barometric pressure (mm Hg)

P_{fa} = average stagnation pressure (mm Hg)

(d) determine Q_s , flow rate as a function of seasonal temperature and P_o/P_s in the look-up table for that specific volumetric flow device. Compare the Q_s with the design specification of the sampler, 36-44 cfm. If Q_s is not between 36-44 cfm, check the temperature used is °F and not °C. Also check the manometer reading is correct with no leaks in the system. Perform a calibration without adjusting or changing any hardware. If the calibration is good, the stagnation pressure should be reaccomplished. If the calibration is not good, perform the failed calibration maintenance(2.5.1.3.2.4.1 m), and recalibrate.

(e) Determine the standard flow rate (Q_{STD})

$$Q_{STD} = 0.392 \times Q_s \times (P_s/T_s)$$

0.392 = standard temperature (298K) / standard pressure (760)

Q_s = flowrate at seasonal average conditions

P_s/T_s = the seasonal pressure / seasonal temperature

Record the calculated Q_{STD} in the A Avg CFM \equiv block on the AQ-41

(f) Determine the standard volume sampled in cubic meters (m^3)

$$V_{STD} = Q_{STD} \times t \times 0.0283$$

V_{STD} = air sampled in cubic meters

t = sampling time in minutes

2.5.2.2.7 After completion of the AQ-41's include all information in 2.5.2.4.1b:

- (a) fold the recorder chart in half (printed side in)
- (b) position the folded recorder chart so that the fold lies along edge of the
- (c) staple the chart to the white copy only,
- (d) forward all samples & forms to the auditor for his review (2.5.5.2.3).

2.5.2.2.8 After receipt from the operator, place the folded filters and AQ-41's in a plastic bag, place the plastic bag in the top of the sample shipping container, lock and seal the container, and attach a shipping label.

2.5.2.2.9 Carry the shipping container to the courier pick-up, UPS pickup, or bus depot. Initial and date the sample station logbook.

2.5.2.3 FILTER INSTALLATION

2.5.2.3.1 In the office or in a protected area, carefully center the pre-weighed filter, rough side up, number side down on the cartridge. Properly align the filter so that the gasket in the hold-down frame forms an air tight seal on the outer edges of the filter. Alternately tighten the plastic pronged knobs to properly seat the gasket. Touch only the edges of the filter, being careful not to tear it. Cover the loaded cartridge with the protective cover. Bring the pre-loaded cartridge to the site.

2.5.2.3.2 Remove six (6) plastic nuts from the PM10 inlet base plate and raise the inlet to the safety catch position.

2.5.2.3.3 Wipe the face plate gasket and the top of the filter adapter with a soft cloth. Inspect the filter screen for holes and excessive bowing, replace if required.

2.5.2.3.4 Read the elapsed time indicator and record on the AQ-41.

2.5.2.3.5 Place the pre-loaded cartridge on the support screen of the filter holder. Flip the timer switch to the "ON" position, then alternately tighten the four (4) nuts, applying only sufficient pressure to hold the cartridge in place.

Excessive pressure can damage the sealing gasket. These are locator studs nuts only, and are not part of the sealing system. The purpose of this procedure is to prevent cracking of the filter media. Flip the timer switch to the "OFF" position.

- 2.5.2.3.6** Lower the sampler PM10 Inlet (head) to the operating position and attach the six (6) knobs. The gasketed flange on the Inlet base plate centers around the inside 7" x 9" opening for the filter cartridge. If the flange is not centered or strikes the filter cartridge knobs, then the filter cartridge may not be properly centered.
- 2.5.2.3.7** Move the timer switch to the "on" position and allow the air flow rate to stabilize for 5 full minutes.
- 2.5.2.3.8** Reset the 7-day timer for the next sampling period. (Routine sampling, every 6th day; emergency or enforcement , as specified).
- 2.5.2.3.9** Label the back of the recorder chart by station number and date of sample and place the recorder chart on the recorder. Check that the pen writes.
- 2.5.2.3.10** Insure the manometer is on and then connected to the stagnation port. At the end of the 5 minute warm-up period and after the air flow rate has stabilized, read the manometer to the nearest one tenth scale division. Record the pressure reading. Convert the ΔP_f (inches H₂O) to mm Hg using this formula: mm Hg = 1.87 x inches H₂O. Use this value to calculate the initial stagnation pressure P_{fi} (36-44 acfm) according to the Look-up table. (see step 2.5.1.3.2.4.1 item # k). If the reading is not in the acceptable range, perform the recalibration maintenance in 2.5.1.3.2.4.1. m, and calibrate under section 2.5.1.3.2.4. If the readings are still not in

the acceptable range, replace the motor and recalibrate. If this fails, return the CFD unit to the ECB for recertification/maintenance. Obtain a replacement if available.

- 2.5.2.3.11** Position the timer switch to "off", reconnect the recorder (if necessary), close and lock the sampler shelter.

2.5.2.4 DOCUMENTATION

2.5.2.4.1 Listed below are the data which must be completed on the AQ-41:

- (a) Filter installation
 - (1) Operator who starts the sampler
 - (2) Sample date
 - (3) Verify that filter number and initial weight are recorded.
 - (4) Station number
 - (5) Sampler number
 - (6) Starting time or ETI reading
 - (7) Initial flow rate
 - (8) Date and initials
 - (9) Summary of any unusual conditions that may affect results (construction activity, land clearing, weather)

- (b) Filter / Sample removal:
 - (1) Operator who removes sample
 - (2) Stop time and elapsed time
 - (3) Final flow rate calculation (attach flow rate chart)
 - (4) Date and initials
 - (5) Summary of existing conditions that may affect results, including reasons for invalid samples.

- (c) Received at the lab
 - (1) Person who receives sample in laboratory
 - (2) Date and initials

For a discussion of the AQ 41 see Appendix M, April 1, 1997

2.5.2.4.2 Sample station e-logbook must be completed as follows:

- (a) Filter number

- (b) Sampler number
- (c) Sample date
- (d) Initial and final flow rates
- (e) Start and stop times and elapsed time
- (f) Operator initials
- (g) Flow rate range determinations
- (h) Flow rate audits
- (i) Flow rate calibration results
- (j) Date samples shipped and initials

Section No. 2.5.2
 Revision No. 4
 Date: October 1, 2001
 Page 23

(Your site name) PM-10 Site Visit Log

Airs# 37-173-0002

Final Time	Elapse min	Start (in H20)	End (in H20)	Initial P _f (mm Hg)	Final P _f (mm Hg)	Avg P _f	avg Atmos Pres mm	avg Atmos Temp	P _o /P _s	Q _s lookup	Q _{std} (cfm)	V _s m3	V _{std} m3	Operator	Ship Date	Remarks
	0			0.00	0.00	0.00	760.00	278.48	1.000		0.00	0	0			
	0			0.00	0.00	0.00	760.00	278.48	1.000		0.00	0	0			
	0			0.00	0.00	0.00	760.00	278.48	1.000		0.00	0	0			
	0			0.00	0.00	0.00	760.00	278.48	1.000		0.00	0	0			
	0			0.00	0.00	0.00	760.00	278.48	1.000		0.00	0	0			
	0			0.00	0.00	0.00	760.00	278.48	1.000		0.00	0	0			
	0			0.00	0.00	0.00	760.00	278.48	1.000		0.00	0	0			
	0			0.00	0.00	0.00	760.00	278.48	1.000		0.00	0	0			
	0			0.00	0.00	0.00	760.00	278.48	1.000		0.00	0	0			
	0			0.00	0.00	0.00	760.00	278.48	1.000		0.00	0	0			
	0			0.00	0.00	0.00	760.00	278.48	1.000		0.00	0	0			
	0			0.00	0.00	0.00	760.00	278.48	1.000		0.00	0	0			
	0			0.00	0.00	0.00	760.00	278.48	1.000		0.00	0	0			
	0			0.00	0.00	0.00	760.00	278.48	1.000		0.00	0	0			

Figure 2.5.2.4.2

2.5.3 LABORATORY PROCEDURES

2.5.3.0 See Lab PM10 QA for procedures.

2.5.3.1 DOCUMENTATION

2.5.3.1.1 The monitoring technician will record sample data on AQ-41 forms and in the e-log book. All scheduled days will have an AQ-41 to document the schedule regardless of the status of the filter, good or bad.

2.5.3.1.2 The lab will record duplicate initial and final weights and date performed in the PM -10 data base on AQ-41 forms.

2.5.3.1.3 Calculate and document on AQ-41 the PM -10 data in ug/m^3 as indicated by 2.5.4.1.3 and record on AQ-41.

2.5.4 DATA HANDLING PROCEDURES

2.5.4.1 DATA PREPARATION

2.5.4.1.1. Keep all AQ-41 data sheets received from the lab. Account for all sites and all samples. Missing data (scheduled) must be explained on an AQ - 41 by the regions. Samples which are void are also to be documented on the AQ-41.

2.5.4.1.2 Screen each form for accuracy, completeness and unusual conditions. Initial and date the "HQ Process " and "Date" blocks on the AQ-41. "HQ review by" will be utilized for exceedances over $155 \mu\text{g}/\text{m}^3$ by the Particulate Chemist.

2.5.4.1.3 Enter the raw data into the ESC data system. The system will calculate the mass concentration of suspended particulates:

$$\text{PM10} = \frac{(W_F - W_I) (10^6)}{(V_{\text{STD}})}$$

PM10 = mass concentration of total suspended particulates,

$\mu\text{g}/\text{m}^3$

W_I = initial weight of filter, g

W_F = final weight of filter, g

10^6 = conversion of g to μg

V_{STD} = air volume sampled corrected to standard conditions
and cubic meters (m^3)

2.5.4.1.4 Perform a data processing check (2.5.5.3.3) on the completed AQ-41 data sheets on a 1 out of 10 basis.

- (a) Recalculate total suspended particulate from AQ-41 raw data and record in logbook.
- (b) If a check result varies $\pm 3\%$ from original calculations, recalculate all samples of that lot.

2.5.4.1.5 Once the data are accepted as mathematically correct, the maximum and minimum concentration of the data shall be examined. If any values are less than $20 \mu\text{g}/\text{m}^3$ or greater than $150 \mu\text{g}/\text{m}^3$, the data technician shall forward those forms to the Particulate Chemist for further investigation.

2.5.4.1.6 Data reported below the minimum detectable limits (mdl) are questionable, but are to be reported using a constant of $1/2$ mdl for the pollutant. The report value for particulate is $0.5 \mu\text{g}/\text{m}^3$. It should be noted that if more than 25% of the measurements for a site are below the mdl the EPA will not compute the annual statistics for that pollutant.

2.5.4.2 DATA SUBMITTAL

2.5.4.2.1 After receipt of the AQ-41's and comments from the Quality Assurance Coordinator (QAC), file all AQ-41's.

2.5.4.2.2 Create the AIRS files when the monthly data has been entered and edited as described above.

2.5.4.2.3 Transfer the AIRS submittal files from the ESC System Software to EPA-NCC for inclusion in AIRS.

2.5.4.2.4 Review the quarterly data reports from AIRS, make changes as needed. When the data in AIRS is complete and correct, prepare the quarterly data submittal letter for the signature of the Chief, Ambient Monitoring Section.

2.5.4.2.5 The Chief will submit to EPA the letter certifying the air quality data for that reporting quarter and indicate the date of the last AIRS "Notify" to update.

2.5.4.2.6 Review the Data Assessment Report (2.5.5.3.10) using AIRS.

2.5.4.2.7 When the Data Assessment Report is complete and accurate, prepare a submittal letter for the signature of the Chief, Ambient Monitoring Section.

2.5.4.2.8 The Chief will submit the Data Assessment Report and the certification letter to EPA.

2.5.4.2.9 The quarterly data and data assessments must be submitted to EPA within 120 days from the end of the quarter.

2.5.5 QUALITY ASSURANCE PROCEDURES

The Quality Assurance program involves running audits to determine statistically the accuracy and reliability of the total set of data. The necessary data must be available to the auditor.

2.5.5.1 PROCEDURES FOR THE OPERATOR

The major part of the operator's role in the quality assurance program is the carrying out of his/her duties in accordance with these operating procedures and performing the following duties.

2.5.5.1.1 Operation of Collocated, Precision Sampler (PM10)

- (a) The location of the collocated sampler(s) will be determined by the QAC.
- (b) Place the precision sampler adjacent (greater than 2 meters and less than 4 meters) to the field sampler previously designated.
- (c) Operate the precision sampler in accordance with Section 2.4 of this plan simultaneously with the field sampler.
- (d) Samples from the field sampler and the precision sampler are not interchangeable. However, results from the precision sampler can be substituted in the event of failure of the primary sampler.
- (e) Identify all precision sampler sample data forms (AQ-41) with County - FIPS Area - Site No. - A.
- (f) Install, collect, and process samples as you would any other sample.
- (g) Take corrective actions as indicated by the QAC on the AQ-100.

2.5.5.1.2 Flowrate Accuracy Audit - This single point check is conducted in the field at each site at the beginning of the second month of the calendar quarter, and reported not later than the first week of the third month of that quarter. See Section 2.5.5.2 for specifics.

2.5.5.1.3 Data Verification

- (a) Check and correct all data routinely as it is recorded.
- (b) Any remarks made are important for further data validation.

2.5.5.1.4 Interagency Testing

- (a) Upon receipt of the reference flow device (RFD) and instructions from the QA Coordinator, an interlaboratory test shall begin.
- (b) All scheduled samplers should be checked.
- (c) The instructions provided by EPA must be followed completely to ensure uniformity throughout the tests.
- (d) Results of each check must be noted in the sample station e-log and reported to the Quality Assurance Coordinator within two working days of receipt of the RFD.
- (e) The RFD should be carefully packaged and shipped or carried to the next field office or EPA as listed.

2.5.5.2 **PROCEDURES FOR THE AUDITOR**

2.5.5.2.0 The Auditor responsibility rests with each Region=s Environmental Chemist II. However some of the duties may be delegated to an operator. This Auditor / operator should be an operator who performs the following duties on those samplers that are **not** his / her primary responsibility.

2.5.5.2.1 Accuracy Audit - An Accuracy Audit is a calibration using a different orifice than the one used to for the quarterly PM10 sampler calibration. The single point accuracy audit/calibration is conducted in the field at each site. This will be accomplished at the beginning of the second month of the calendar quarter. The following is the calibration procedure adjusted for an accuracy audit. It will be calculated using both current ambient and seasonal averaged data.

2.5.5.2.1.1 AUDIT(CALIBRATION) PROCEDURE

The volumetric flow-controlled sampler will be calibrated at one point near the design flowrate of (40 acfm). Periodic calibrations every 3 months (less than 91 days) are required to establish accuracy and consistency. These calibrations are normally in conjunction with a motor change.

Calibration equipment:

Orifice Transfer Standard (traceable to a rootsmeter).

2 Manometers (4+4" H₂O to 0.1 inch) and (12+12" H₂O to 0.1 inch)/or

electronic manometers verified by ECB

Thermometer [certified in degrees Centigrade converted to K]

Barometer, certified, read to nearest mm Hg

PM10 filter

SEE NEXT PAGE

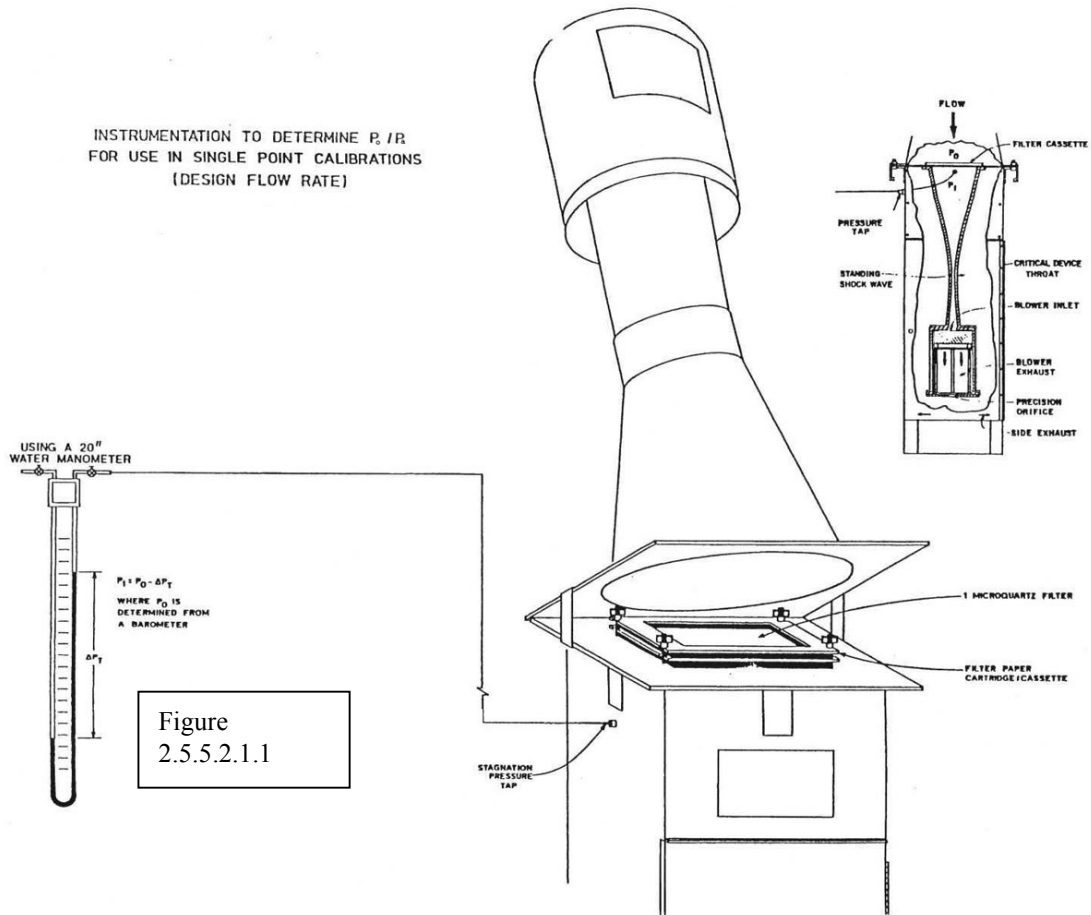

- (a) Upon arrival at the site allow equilibration of a certified thermometer, record the ambient temperature (T_a) and ambient pressure (P_a) on the PM10 e-logbook.
- (b) Install the calibration orifice and a PM10 filter on the sampler. Turn on the sampler and check for leaks by blocking all open ports. **WARNING:** DO NOT CONNECT THE MANOMETER TO THE CALIBRATION ORIFICE (ΔH) UNTIL THIS LEAK TEST IS COMPLETED. Do not run the leak check more than 30 seconds. Listen for any whistling sound that may indicate faulty gaskets or cross threading. Ensure that the filter screen is properly aligned with the top loading adapter. If not, adjust the screen forward and backward until the gasket seals the top of the filter screen correctly. If the unit still leaks, retighten or realign and retest until leaks are found.

- (c) Zero the manometers being used.
Water manometers are adjusted to zero by:
1. insuring the vents for each side are open (turned counterclockwise)
 2. loosening the retaining device and sliding the scale so that both sides of the U-tube are zeroed at the bottom of the water meniscus, retighten the retaining device
- Electronic Manometers:
1. Turn on (push the **on** button)
 2. Zero (push the **zero** button, without being attached to the sampler)
- (d) Connect one side of the large manometer to the stagnation port pressure tap located on the side of the sampler housing (ΔP_f), see figure 2.5.5.2.1.1, and leave the other side open to the atmosphere. (The quick connect located on the station housing closes automatically when the manometer is disconnected.) Connect the orifice to the small manometer. Insure the electronic manometer is "on" before connecting to any port. **CAUTION: If the electronic manometer is "OFF" when connected, damage to the diaphragm may result.**)
- (e) Turn on the sampler motor. Insure it is allowed to warmup for 5 minutes.
- (f) While waiting, record on the PM10 e-log audit sheet: date, location, operator, sampler motor number, CFD S/N , orifice S/N and the orifice PM-10 calibration slope and intercept.

	SITE NAME		AIRS NUMBER		DATE	QUARTER	OPERATOR	
	Lexington		371230004		2/3/01			
	ORIFICE #		ORIFICE CERT DATE			m	b	
						0.1918	-0.5212	
	P _a		T _a	T _K		P _{avg}	T _{avg}	
			22.0	295.00		760	288	
Filter	H (in H ₂ O)	P _f (in H ₂ O)	P _f (mm Hg)	P _o /P _a	Q _a (acfm)	Q _a (orifice)	% Diff	
End Cal	5.2	20.5	38.34	0.950	41.88	#DIV/0!	#DIV/0!	
Begin Cal	5.2	22.5	42.08	0.945	41.88	#DIV/0!	#DIV/0!	
% Diff must be less than 6%. If not <i>recalculate</i> using actual temp & pressure.								
If not < 6%, investigate, correct, and reaccomplish next Audit. If still > 6% call ECB.								
Q _a (orifice) This value must be 40 acfm +/- 4 acfm. If not reaccomplish next Audit.								
If still > +/- 4 acfm call ECB.								
				Do Not Fill in/Overwrite the red cells				
Comments				Only fill/write in the yellow cells				

Figure 2.5.1.3.3.2

- (g) After 5 minutes, record the funnel pressure (ΔP_f) and the orifice pressure (ΔH).
- (h) Convert the ΔP_f (inches H₂O) to mm Hg using this formula:
mm Hg = 1.87 x inches H₂O, Record on calibration e-log.
- (i) Calculate the CFD pressure ratio P_o/P_a :

$$P_o/P_a = \frac{(P_a - P_f)}{P_a}$$

where P_a = ambient pressure, and P_f = funnel pressure (both in mm Hg)

- (j) Determine the calibration orifice flow rate, Q_a (ACFM):

$$Q_a = \frac{((\Delta H \times 25.4 \times T_a/P_a)^2) - b}{m} \quad \text{Note: } (x)^2 = \text{Square root } x = \sqrt{x}$$

Where T_a = ambient temperature ° Kelvin = ° Centigrade + 273

P_a = ambient pressure in mm Hg

m and b are the slope and intercept for the orifice.

- (k) Determine the expected flow rate for the funnel, Q_f . Go to the Look-up

table for the CFD and use the temperature in °F = ((°C x 9/5) + 32) and the pressure ratio P_o/P_a to determine the CFD expected flow rate. Interpolation may be required for the actual temperature.

- (l) Determine the percent difference:

$$\text{Percent difference} = \frac{Q_f - Q_a}{Q_a} \times 100$$

The audit (Calibration) calculation using ambient temperature / barometric pressure checks the validity of the calibration conducted with another calibration orifice. For Audit calculations using current ambient data, the percent difference between the Orifice flow rate (Q_a) & the expected look up flow rate (Q_f) must agree $\pm 4\%$. **Record in the sampler log only.**

The calculation using seasonal average temperature and barometric pressure will validate the run data using the seasonal averages. For Audit calculations using the seasonal average data, the Percent difference between the Orifice flow rate (Q_a) & the expected look up flow rate (Q_f) must agree $\pm 6\%$. **Record in the sampler log and AQ-41.**

- (m) **If the Calibration % difference is > 4%, Troubleshoot the calculations & the sampler:**
Recheck the orifice transfer constants and calculations of the calibration procedure. Check for manometer reading errors and incorrect temperature or pressure data. Make sure the serial numbers for the hardware and the lookup tables match. Recheck the system for leaks. Inspect the CFD for debris or corrosion in the throat. If necessary clean with soap and water. If still not within $\pm 4\%$ Check that line voltage is ≥ 110 v AC. Inspect for blower motor, check for adequate brushes and gaskets. If necessary, change existing motor and brushes and recalibrate.
- (n) If all efforts to calibrate fail, return the CFD and motor to the Electronics and Calibration Branch for replacement.
- (o) **If the Audit % difference is > 6%,** but the calibration is ok, check for temperatures and barometer value extremes from the seasonal. Extreme values are considered greater than 40mm Hg or 20EC. If seasonal values are considered extreme and the calibration is good, the audit passes. However, if seasonal values are less than

extreme, recheck hardware as in item m above.

2.5.5.2.2 AUDIT SCHEDULING

The audit schedule must be followed quarterly and implemented. Duties for both the monitoring tech, and the auditor need to be included since some actions need to be taken, by both, thus requiring the planning of each person's time.

- (a) Audit (PM10) scheduling
This check requires that a one point audit check be performed at the beginning of the second month of the calendar quarter and within three months use after maintenance. Increase the auditing rates if defects are detected, until the defects can be demonstrated corrected.

- (b) Collocated Precision Sampler (PM10)
The same schedule is required for the precision sampler, since it operates simultaneously with the field sampler. Each audit sampler must be audited in accordance with other auditing procedures of 2.5.5.

2.5.5.2.3. AUDITOR REVIEW

- (a) Collocated Precision Sampler (PM10)
 - (1) Review, initial and date the additional AQ-41's for audit sampler. It is suggested that the auditor occasionally question the operator to be sure that the audit sampler and samples are not receiving preferential treatment.
 - (2) If an Audit Evaluation form is received from Q.C. for a collocated sampler, the auditor will assure that any necessary corrective action be taken.

- (b) Audit (Calibration) (PM10)
 - (1) The field work for the single point checks may be performed by the operator during the quarter.
 - (2) Obtain the actual and measured audit flow rates from AQ-99. Calculate the individual percent difference (d_2) for each station

for each audit value as follows:

$$d_2 = \frac{(Q_o - Q_a) \times 100}{Q_a}$$

Q_o = the observed flow rate (40 scfm)

Q_a = the actual flow rate in CFM determined for that orifice.

- (3) Obtain the single point check d_2 from the AQ-99. If more than one audit is run, calculate each d_2 and use this value as a separate audit (i.e., separate site) using the above equation.

2.5.5.2.4 AUDIT EVALUATION AND ACTION

After each audit, the auditor must evaluate the d-values.

(a) Calibration Check (PM10)

- (1) If d_2 is greater than 4.7 in magnitude ($d_2 > 4.7$), then ;

- (a) increase the auditing rate to two times/quarter
- (b) perform special checks to identify trouble areas
- (c) take necessary action to reduce error level

- (2) If d_2 is greater than 7 in magnitude ($d_2 > 7$) then terminate operation of the sampler until the cause has been determined and corrected.

(b) Documentation

When a defect is detected, enter the following information in the sampler e-log.

- (1) the date the evaluation was made
- (2) results of the evaluation
- (3) any increase in audit level
- (4) type of corrective and preventative action taken
- (5) the results of the audits following the corrective action
- (6) the date acceptable data collection was resumed
- (7) **Immediately send a copy of the AQ-100 to the QA coordinator.**

2.5.5.2.5 DATA VERIFICATION

- (a) All sample forms must be initialed by the auditor.
- (b) Before initialing, check form for completeness and correctness.

- (c) Screen the sample and form for representativeness
 - (1) Is the sample representative of the area ?
 - (2) Was there an unusual situation noted by the operator?
 - (3) Instrument averaging time 24 hrs \pm 1 hr.

NOTE: Samples having abnormalities must be flagged by a check at the top of the AQ-41 in the "Data Validation" block.

2.5.5.2.6 SELF EVALUATION

Each auditor shall complete a Self-Evaluation Form when requested by the QAC.

2.5.5.3 PROCEDURES FOR THE HEADQUARTER'S STAFF

2.5.5.3.0 The Quality Assurance Coordinator (QAC)

- (a) The Quality Assurance Coordinator shall evaluate and retain all quality assurance data indicated by this manual including all QADR forms, Data Qualification forms, and Audit Evaluation forms. A check of each Audit Evaluation form should include verification that the necessary corrective and preventative actions have been completed.
- (b) A check that regional auditors have set up and implemented auditing schedules must be made by the QA coordinator.

2.5.5.3.1. Collocated Precision Sampler - Data Technician

- (a) After obtaining both the field sampler AQ-41 and the audit sampler AQ-41 for a site, review the data for completeness and accuracy and correct any errors.
- (b) Calculate the final concentrations of PM10 for each AQ-41.

- (c) Calculate the percent differences(d_{1j}) for each pair of PM10 values($PM10_{FJ}$) as follows:

$$d_{1j} = \frac{PM10_{aj} - PM10_{fj}}{\frac{PM10_{aj} + PM10_{fj}}{2}} \times 100 \quad \text{where:}$$

$PM10_{fj}$ = Conc. from field sample
 $PM10_{aj}$ = Conc. from precision sample

- (d) Record each $PM10_{fj}$, $PM10_{aj}$, and d_{1j} in the Data Qualification forms. If any d_{1j} is greater than $\pm 25\%$, prepare an Audit Evaluation Form for the QAC to send to the responsible regional office.

2.5.5.3.2 DATA VALIDATION - DATA TECHNICIANS

- (a) Keep a record of all AQ-41 data sheets received so that for each sampling date all sites and samples are accounted for. Samples which are void are also documented.
- (b) Screen each form for accuracy, completeness and unusual conditions. Initial and date the "Data Edit" and "Date" blocks.
- (c) After the completion of the routine sample calculations (2.5.4.1.3), perform the data process check (2.5.5.3.3) below.
- (d) Once the data are accepted as mathematically correct, the maximum and minimum concentration of the data shall be examined. If any values are less than $20 \mu\text{g}/\text{m}^3$ or greater than $150 \mu\text{g}/\text{m}^3$, the data technician shall forward those forms to the QAC for further investigation.
- (e) Data reported below the minimum detectable limits (mdl) are questionable, but are to be reported using a constant of 2 mdl for the pollutant. The report value for particulate is $0.5 \mu\text{g}/\text{m}^3$.
- (f) Notify the AIRS contact to submit the data to AIRS when all calculations have been completed and all data processing checks have been passed.
- (g) After the data are electronically submitted to AIRS, check the AIRS printout to verify that every expected sample is complete and accurate.
- (h) File the AQ-41 forms in the data file cabinet.

- (i) Prepare and forward the AIRS data submittal letter showing the date of the last AIRS NOTIFY for the quarter for the signature of the Chief, Ambient Monitoring Section.

2.5.5.3.3 Data Processing Check

- (a) A Data Technician will randomly choose one (1) sample out of a lot of 10. All final concentrations will be recalculated from raw data. (See 2.5.4.1). The original particulate concentration must be obtained from the AQ-41.
- (b) Calculate the percent difference as follows:

$$d_{4j} = \frac{PM10_{oj} - PM10_{cj}}{PM10_{cj}} \times 100$$

where:

d_{4j} = percent difference between calculations for the j th check of the quarter

$PM10_{oj}$ = originally calculated value for total suspended particulate to be used in the j th check of the quarter

$PM10_{cj}$ = check calculation obtained through (a) above

- (c) Record the d_{4j} in the Data Process Check Logbook.
- (d) Evaluate the d_{4j} values. If all d_{4j} values for a station for the quarter are $-3 \leq d_{4j} \leq +3$, then all $PM10_{oj}$ are accepted as good. If one of the d_{4j} values exceeds these limits, then the entire set of that type of sampling data for that date shall be recalculated.

2.5.5.3.4 Data Validation - QA Coordinator (QAC)

- (a) The QAC is responsible for the validity of all air monitoring data. The activities and records of the Data Technicians should be checked as needed.
- (b) Any evaluations of questionable data may include, but not be limited to, the following:
 - (1) Statistical evaluation to determine if the questionable value is statistically an outlier (See Appendix of EPA-600/9-76-005),

- (2) An investigation as to possible causes at the site,
- (3) Rejection of the value if it is not found to be satisfactory and identification of the unusual acceptable values.
- (4) Evaluation of unnecessary delay in processing ambient samples.

2.5.5.3.5 Elapsed Time Between Sample Collection and Analysis(D_i)

- (a) A data technician will record D_i on the AQ-41 for each sample. If D_i >15, then check the Data Validation block on the AQ-41. Contact the responsible regional office or laboratory for explanation of undue delay in sample processing.

2.5.5.3.6 Data Reporting and Forms

- (a) Previous sections of this part have indicated which forms should be used for data reporting.
- (b) Section B of the Appendix presents examples of each form.

2.5.5.3.7 Determination of Probability Limits

The following calculations are now routinely calculated automatically by the EPA-AIRS software. Manual calculations are not usually performed.

- (a) Pooled Precision Difference - Collocated Samplers
 - (1) Obtain the PDQARF and CMQAR forms from the QAC at the end of each calendar quarter. Obtain the d_{1j} values for each collocated sampler site.

- (2) Average all d_{1j} for a site as follows:

$$\bar{d}_1 = \frac{d_{11} + d_{12} + d_{13} + \dots + d_{1j}}{j}$$

j = no. of collocated samples at a site per quarter

=

- (3) Quarterly, calculate the agency pooled % difference (\bar{d}_1) as follows:

$$\bar{d}_1 = \frac{N_1 \bar{d}_1 + N_2 \bar{d}_2 + \dots + N_k \bar{d}_k}{N_1 + N_2 + \dots + N_k}$$

\bar{d}_{1n} = the average percent difference for each site, n
 k = the number of sites
 N = the number of collocated pairs at each site

- (4) Record the \bar{d}_1 on the CMQAS.

- (b) Pooled Accuracy Difference - Calibration Check

(1) Obtain the CMQAR forms from the QAC at the end of each calendar quarter. Obtain the \bar{d}_2 values for the entire agency. Complete the ADQARF forms according to 40 CFR 58 instructions.

- (2) Calculate the agency average percent difference (\bar{D}_2) as follows:

$$\bar{D}_2 = \frac{\sum \bar{d}_2}{n}$$

n = number of audits reporting a \bar{d}_2

- (3) Record the \bar{D}_2 on the CMQAS

2.5.5.3.8 Interagency Testing

- (a) The State of North Carolina will participate in the EPA NPAP interagency flow rate studies.
- (b) The interlaboratory flow rate study is conducted by EPA. Instructions are provided by the EPA and these instructions may vary from test to test, therefore, no specific procedures will be included in this part.
- (c) The State of North Carolina will participate in all interagency particulate studies when possible. In addition to reporting the results to EPA's Quality Assurance Branch, an inter agency

evaluation will be made of the results and corrective actions will be taken when necessary.

- (d) Interagency Testing General Procedure
 - (1) Upon receipt of the reference flow device(RFD) and instructions from EPA an interlaboratory test shall begin.
 - (a) The QAC shall develop a list of the field offices to receive the RFD.
 - (b) The QAC shall ship the RFD and instructions to the first field office on the list.
 - (c) Upon receipt of the results from each field office, the results will be reviewed and prepared for submittal to EPA. An evaluation will be made of the results and corrective action taken. The QAC shall initiate any corrective actions.

2.5.5.3.9 Systems Auditing - QA Coordinator

- (a) A systems audit (qualitative appraisal of the total measurement system) should be conducted at the start-up of a new monitoring system and at least once per year thereafter. The state QA Coordinator will evaluate the monitoring activities of each local agency and the state's operations using EPA provided forms. Procedures will be checked for methods and equipment; installation of equipment; calibration; operational checks, frequency of checks; control limits for flowrate; maintenance, quality control for episodes; data validation and recording; and quality control documentation. For the annual audit, EPA will then review the findings of the QAC.

2.5.5.3.10 Quality Assurance Reports

There are two levels of reporting which are necessary:

- (a) Reports defining the quality of the data to EPA.
- (b) Reports to Air Quality Management defining the status and results of the QA Program.

2.5.5.3.10.1 Reports to EPA - Quarterly Data Assessment

Section 2.5.5.4.7 describes the methods by which probability limits are established. These limits are used directly in reporting the quality of collected particulate data. Data reported to EPA shall be accompanied by the probability limits for each pollutant on a reporting agency basis. EPA Data Assessment Forms will be completed according to EPA instruction. (See Appendix B.2.3.9 for the form and instructions.)

2.5.5.3.10.2 REPORT TO AIR QUALITY MANAGEMENT

The quality assurance facts listed below shall be determined on a quarterly basis.

- (a) Pooled precision and accuracy for each pollutant and levels on an agency-wide basis.
- (b) Status of solutions (corrective action) of major quality problems.
- (c) System audit results - a written qualitative appraisal of how well the QA program is working. This shall be done annually by the QAC.
- (d) A discussion of any interagency quality assurance tests.

Appendix M

M.0 APPENDIX M, CHAIN OF CUSTODY PROCEDURES FOR PARTICULATE ENFORCEMENT SAMPLES

The purpose of this appendix is to ensure that the Division of Air Quality complies with Chain of Custody (CoC) requirements for potential enforcement cases. The Chain of Custody is a document that traces the unique number identified sample/filter from initial weighing to final analysis and storage. The CoC ensures the data collected in support of enforcement actions are admissible in an administrative court and the sample meets the judicial standards for proper procedural requirements. An essential part of all enforcement investigations is that any evidence gathered be documented as controlled and uncompromised. Documentation of sample possession during preparation, collection, and analysis is provided by following CoC procedures. **Chain of Custody procedures must be followed for all enforcement samples.**

M 1.0 AQ-41

Particulate concentration data from intermittent samplers can be used for enforcement sampling. The AQ-41 is the CoC and particulate sample data sheet. All particulate samples utilize the AQ-41, however the shaded (CoC) area on the AQ-41 must be completed for all enforcement samples. The Regional Chemist II is responsible for adherence to CoC procedures by all regional personnel.

M 1.1 GENERAL PROCEDURES

All persons in possession of the sample/filter from initial weighing to final storage must be identified as to when (time and date) they were in possession/control of the filter. This documentation notes the unbroken chain of responsible individuals in possession of the filter during times when the filter is not in a locked storage or in a sampling condition. As few persons

as possible should handle the sample. A security seal will be used for transfer of filters by state couriers and state employees that are transporting the filter. This seal will be attached to a locked container that can not be opened without damage to the seal. Documentation of those transporting a Locked/Sealed box is not required. Only those breaking the seal and those handling the filter must be documented on the AQ-41. Each person will document the security condition of the sample upon receipt. It must be locked and sealed during courier transport and locked when not under direct control of persons actually sampling or processing.

M 1.2 SPECIFIC PROCEDURES

Particulate filters are identified by the manufacturer with a unique number for each filter. This number will become the filter and sample identifier for a designated sampling date. The corresponding AQ-41 accompanying each filter will also be identified with this number. Recorder charts and other supporting documentation will use the pollutant name, the sample site name, and the date sampled to identify it. This ancillary information will also be on the AQ-41

M 1.2.1 The AQ-41 is initiated with the initial weighing of the filter by the laboratory technician. The AQ-41 will remain with the filter throughout its process. The filter identifier is completed at the lower left side and is the same number as found on the filter. The lab technician completes the shaded lab area with the date weighed, initials, and the date placed into locked lab storage. These two dates must be the same.

M 1.2.2 The technician shipping the filter from the lab storage area to the region completes the remaining AQ-41 lab area for shipment. The technician will initial and date each AQ-41/filter from storage and sign that it was relinquished to the locked and sealed shipping container. Then identify the type of courier.

M 1.2.3 The regional individual opening the locked and sealed container will notice the condition received, i.e., Locked /Sealed(L/S). After opening, this person will circle (L/S) block 1 signifying the security condition that he/she received the container, sign block 2, and complete date received in block 3. (If the container is not received in this Locked/Sealed condition, it will be returned to the lab for revalidation of the filter.) This person will then sign the "Locked & Relinquished By" block 4, and immediately store the filter and AQ-41 together in the designated regional locked storage .

M 1.2.4 Prior to visiting the sample site, the Air Quality Technician opening the locked storage will observe the security condition of the regional storage. The individual will remove the filter and corresponding AQ-41. He/she will document the security condition of storage(i.e. locked) on the AQ-41 once available, block 1. (If the lock is found unlocked, consult the Chemist II and headquarters. Enforcement filters exposed and clean may have been compromised.) The Technician will sign block 2, and complete the date and time of opening, block 3.

M 1.2.5 The Technician must use the secured Technician's Container to transport filters to and from the sites. Sign block 4, "Relinquished By". Place the filter and AQ-41 into the Technician's Container and lock the container using the Technician's Container lock.

NOTE: EXPOSED FILTER REMOVAL The procedural sequence used follows one filter through the entire process. Realize that when you arrive at the site with a new filter, that the old filter must be removed using M 1.2.7. Hence, when you arrive at the sampler, note the security condition. Be sure to document the arrival security condition on the AQ-41 corresponding to the filter(exposed) in the sampler.

M 1.2.6 NEW FILTER INSTALLATION: The technician will open the "Technician's Container"; note the "Technician's Container" security condition(locked); circle the security status block 1, sign that it was opened block 2, complete Date/Time block 3; and sign the "Relinquished By" block 4 To Sampler. Install the filter into the sampler. Place the AQ-41 into a document protector secured in and locked within the sampler.

M 1.2.7 Note the security condition of the sampler site for documentation on the AQ-41. Open the sampler and complete the security of the sampler block 1 upon arrival. Be sure to use the AQ-41 corresponding to the exposed filter(circle yes, if appropriate). The technician signs block 2, from sampler, and completes Date/Time block 3. Sign block 4 "Relinquished By". Place the exposed filter and corresponding AQ-41 into the "Technician's Container" and immediately lock the container.

M 1.2.8 Upon arrival at the regional storage area, the technician will open the container and annotate on the AQ-41 the security condition of the "Technician's Container" block 1, circle yes. Sign block 2 and document Date/Time block 3. Sign the "Relinquished By" block 4 demonstrating that the filter was again locked in the "Region Storage". Place the filter and AQ-41 into storage and lock.

M 1.2.9 The Auditor must review the AQ-41 for completeness and accuracy. This next line is for the Auditor to document the handling of the AQ-41 and filter. The Auditor must document the status of the region's storage(locked) in block 1, sign that he opened it (block 2), document time/date block 3, and later sign that he had completed the form review and that form and filter were relinquished (block 4) back to the regional storage.

M 1.2.10 The person shipping the filter/AQ-41 to the Lab must open the regional storage and note its security condition(locked), document the AQ-41 by circling yes in block 1, sign block 2, fill in Date/Time in block 3, and sign the relinquished by block(4) to the "To Shipping Container". This person then denotes the security condition(Locked/Sealed), the anticipated date that the container will be shipped to the lab, and method of shipment(State Courier). Only fill in a different courier type if appropriate. The AQ-41 and filter are then locked and sealed in the "Shipping Container". Use the shipping lock, not the operators lock for the "Technician's Container" used during sampling.

M 1.2.11 After arrival at the lab, the person opening the Locked/Sealed container will document on the AQ-41 the security status (Locked/Sealed), sign "Unlocked/Unsealed By", "Date/Time opened", sign "Lab CoC Initiated By" blocks. At this time the **Lab chain of custody will be initiated** for the storage and analysis. The original AQ-41 will remain with the sample at the laboratory. All CoC, field, and lab data will be retained with the filter in the laboratory filter storage area under lab custody procedures. The yellow and pink copies of the AQ-41 with the field and lab data will be forwarded to headquarters for further processing after all lab analysis has been completed.

Section No. M
Revision No. 1
Date: April 1, 1997
Page 6 of 6

NORTH CAROLINA DIVISION OF AIR QUALITY
PARTICULATE MONITORING DATA SHEET (24 HOURS)

Lab No. A
~ Void Filter
~ Radiation
~ Metals
~ Enforcement
~ Emergency Episode
~ Special Study
~ Microscopy
~ Collocated
~ Data Validation
Regional

Office AIRS Code 37-
Site Name AQCR

T One	Pollutant	Method	Unit	Dec	YY	MM	DD	ST HR	µg/m ³	PM Only
	TP 11101	091	001	0						Ps= mmHg
	APM 81102	063	001	0						TS= K
	WPM 81102	062	001	0						

≠ PRESAMPLING CHAIN-OF-CUSTODY THAT LAB COMPLETES FOR ENFORCEMENT SAMPLES ONLY +

Init Weighing Date	Lab Tech	Storage Location	Date/Time removed	Locked, Sealed & Relinquished by	Courier
Date	Sign	Date	From Storage/ Initials	to Courier	Type
1.2.1			1.2.2		

≠ CHAIN-OF-CUSTODY THAT REGION COMPLETES FOR ENFORCEMENT SAMPLES ONLY +

Locked/sealed (L/S) (1)	Signature or Status (2)	Date/Time (3)	Relinquished By (4)	Disposition
L / S Yes No	Box Opened By @ Region 1.2.3			Region Storage
Locked Yes No	Storage opened by 1.2.4		1.2.5	To Technician=s Container
Locked Yes No	From Technician=s Container 1.2.6			To Sampler
Locked Yes No	From Sampler 1.2.7			To Technician=s Container
Locked Yes No	From Technician=s Container 1.2.8			To Region Storage
Locked Yes No	From Region Storage 1.2.9			To Region Storage
Locked Yes No	From Region Storage 1.2.10			To Shipping Container
L / S Yes No	Anticipated date Container Shipped to Lab +			Courier(type)

FIELD INFORMATION OPERATOR COMPLETES FOR ALL SAMPLES

Installed By	Removed By
Date/Time	Date/Time
Remarks	Remarks

Please Staple Recorder Chart
To White Sheet Only
Here

VFC Sampling Rate			Total Volume Sampled, M ³	Elapsed Time (Minutes)		
Start	End	Qstd CFM		Final	- Initial	= Total
X	X	X		X	X	X

RO Reviewed By:	Date	Remarks
-----------------	------	---------

Mass Flow Sampling Rate (OLD TSP)			Total Volume Sampled, M ³	Elapsed Time (Minutes)		
Start	End	Avg CFM		Final	- Initial	= Total
X	X	X		X	X	X

RO Reviewed By:	Date	Remarks
-----------------	------	---------

≠ POSTSAMPLING CHAIN-OF-CUSTODY THAT LAB COMPLETES FOR ENFORCEMENT SAMPLES ONLY +

Security Condition	Unlocked/Unsealed By	Date/Time Opened	Lab CoC Initiated By
L / S Yes No			
1.2.11			

PARTICULATE LABORATORY ANALYSIS COMPLETED FOR ALL SAMPLES

Filter No.	Final Wt.	Initial Wt.	Total Particulate	Other
	X	X	X	X
Reweighs	Final	Initial	Date of Analysis	
	X	X	Data Entry By:	Checked By:

Laboratory Remarks
HQ Review By: Date: HQ Process: Remarks