

Hydrocarbons: Probe Installation, Sampler Installation, Removal and
Electronics Repair
Section I

Electronic Calibration Branch (ECB) Responsibilities

Approval Sign-Off Sheet

I certify that I have read and approve of the contents of the " Hydrocarbons: Probe Installation, Sampler Installation, Removal and Electronics Repair QA Plan, Section I, Electronic Calibration Branch (ECB) Responsibilities" with an effective date of October 27, 2010. **Sign, date and return to the Ambient Monitoring Section Chief.**

Joette Steger, PPB Supervisor: Joette Steger 7/29/2011
Donnie Redmond, Ambient Monitoring Section Chief: Donnie Redmond 7/29/11
Frank Stelitano, ECB Supervisor: Frank R. Stelitano
Carlton Blakley, Environmental Chemist: Carlton Blakley 10/27/10

Table of Contents

2.18.1 Hydrocarbon QA Plan: ECB Responsibilities 4

2.18.1.1 PROBE INSTALLATION, SAMPLER INSTALLATION – REMOVAL and
ELECTRONICS REPAIR 4

2.18.1.1.1 OBJECTIVES 4

2.18.1.1.2 Probe Equipment..... 4

2.18.1.1.3 Probe Installation 4

2.18.1.1.4 Preventive Maintenance..... 5

2.18.1.2 Sampler Equipment..... 6

2.18.1.3 Sampler Installation 6

2.18.1.4 Sampler Removal..... 7

2.18.1.5 Sampler Electronics Repair..... 7

Table of Figures

Figure 1 Probe Installation Diagram..... 5

Figure 2 Probe Installation Diagram..... 6

Figure 3 NMOC Sampler..... 7

Figure 4 Electronic Seven-Day Timer 8

2.18.1 Hydrocarbon QA Plan: ECB Responsibilities

Note: The following is a list of "significant changes" from Revision 1.0.

1) QA updated per QAP/SOP 2.39 "Standard Operating Procedure (SOP) for Preparing Quality Assurance Plans/SOPs".

2.18.1.1 PROBE INSTALLATION, SAMPLER INSTALLATION – REMOVAL and ELECTRONICS REPAIR

2.18.1.1.1 OBJECTIVES

The installation procedure described in this section applies to the sampling probe and sampler equipment used to draw in an electrically timed volume of air (non methane organic compounds (NMOG) hydrocarbons) associated with ambient air sampling.

2.18.1.1.2 Probe Equipment

Chromatographic grade stainless steel tubing is used as a conduit to transport sample air from the atmosphere at the required sampling height and distribute it for collection. An excess of sample air is pulled through the sample probe to ensure that the sample air is representative of outside ambient air.

2.18.1.1.3 Probe Installation

a. Site selection^a - Prior to being placed in operation, the probe must be placed to avoid introducing bias to the sample. Important considerations are probe height above the ground; probe length, and physical influences near the probe. Some general guidelines for probe placement are:

- The probe should not be placed next to air outlets such as exhaust fan openings.
- The probe should not be near physical obstructions such as chimneys that can affect the air flow in the vicinity of the probe.
- The probe must be located away from obstacles and buildings such that the distance between the obstacles and the probe is at least twice the height that the obstacle protrudes above the probe.
- The probe must be >20 meters from the drip line of tree(s) and must be 10 meters from the drip line when the tree(s) act as an obstruction.
- Height of the probe or at least 80% of the monitoring path must be 3 -15 meters above the ground.
- Height of the probe above supporting structures should be >1 meter.
- Placement of the hydrocarbon sample probe is 1 meter from the CO monitor probe.

- There must be unrestricted airflow in an arc of at least 270 degrees around the probe inlet.

2.18.1.1.4 Preventive Maintenance

a. Stainless Steel Tubing / Fittings - any time fitting(s) will not thread properly, replace the fitting.

b. Cleaning – ECB will inspect sample probe annually and replace the stainless steel probes every two years. If there is a problem with sample analysis reported by HC Lab and a dirty probe is suspected, a "through – the – probe " audit will need to be conducted or the line changed.

c. Check Valves – inspect the airflow check valve screen before it becomes plugged. Replace as needed.

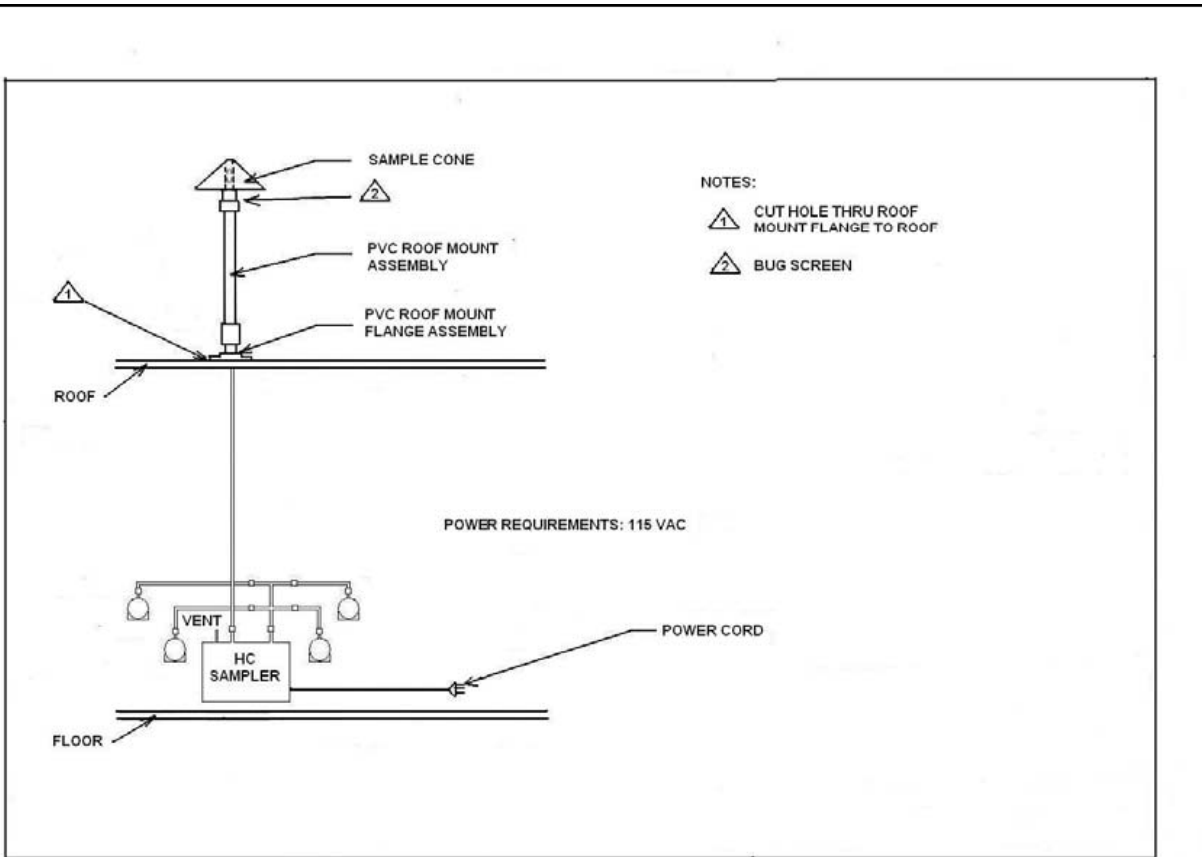

Figure 1 Probe Installation Diagram

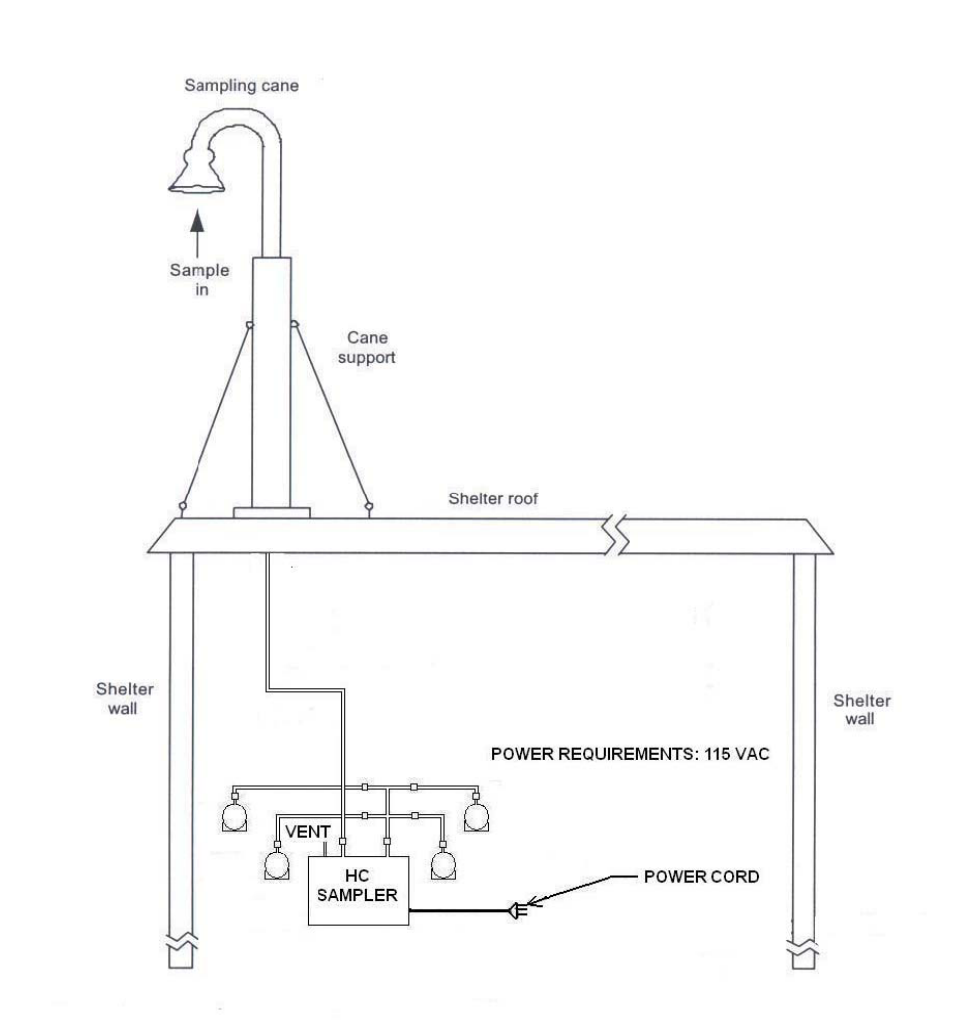

Figure 2 Probe Installation Diagram

2.18.1.2 Sampler Equipment

The ambient air sampler is an electrically powered (115 volt AC) sampling system that consists of a sampling pump, two four event timer mechanisms which can be programmed to sample air seven days a week within a twenty-four hour time period and elapsed time meters.

2.18.1.3 Sampler Installation

- a.** The air sampling equipment is installed in the site housing and connected to the sampling probe.
- b.** Do not connect the sampling system to the 115-volt AC circuit as site technicians will set this.

2.18.1.4 Sampler Removal

- a. Disconnect the sampling system from the 115-volt AC circuit.
- b. Cap off the sample system inlet with a 9/16 " Swagelock cap.
- c. Secure the electrical system chord.

2.18.1.5 Sampler Electronics Repair

If the HC Lab experiences problems with the sampler electronics, the technician contacts the ECB. The ECB will fill out a 109 form to make the repairs.

1) The electronics consists of:

- a) keypad timers – if there is no LED readout (**On Indicator Light**) or no command functions, replace either the keypad or the keypad unit. Timers have a battery back up to provide power in case there is a power outage. Replace batteries as needed.
- b) elapsed time meters – if one of two programmed elapsed timers failed to operate, check voltage and replace if necessary.
- c) solenoids – if one of two programmed solenoids fails to open, replace unit.
- d) pumps – if one of two pump fails to operate, replace unit.

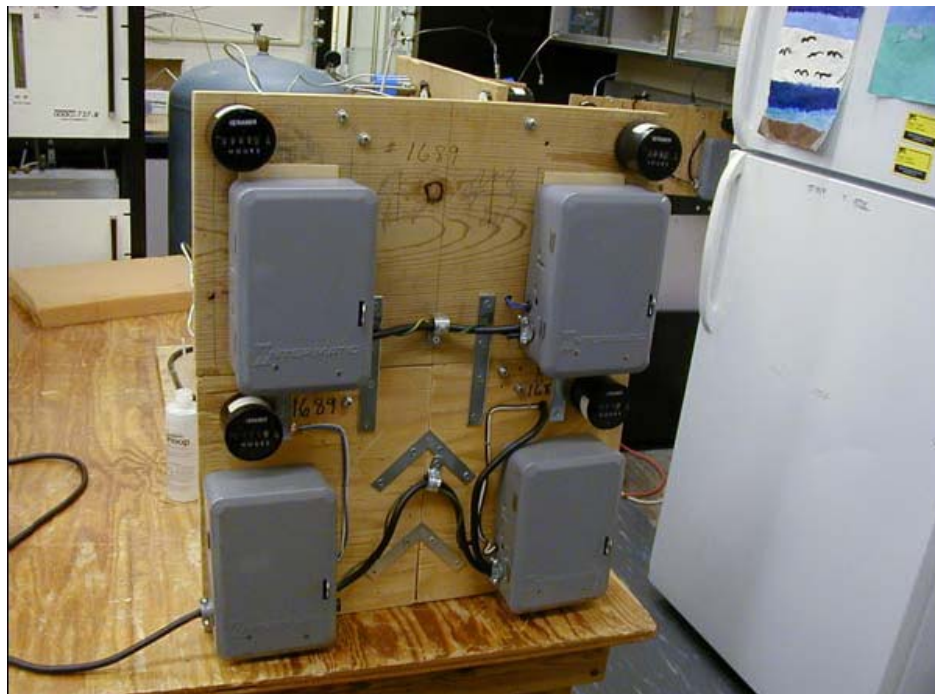

Figure 3 NMOCSampler

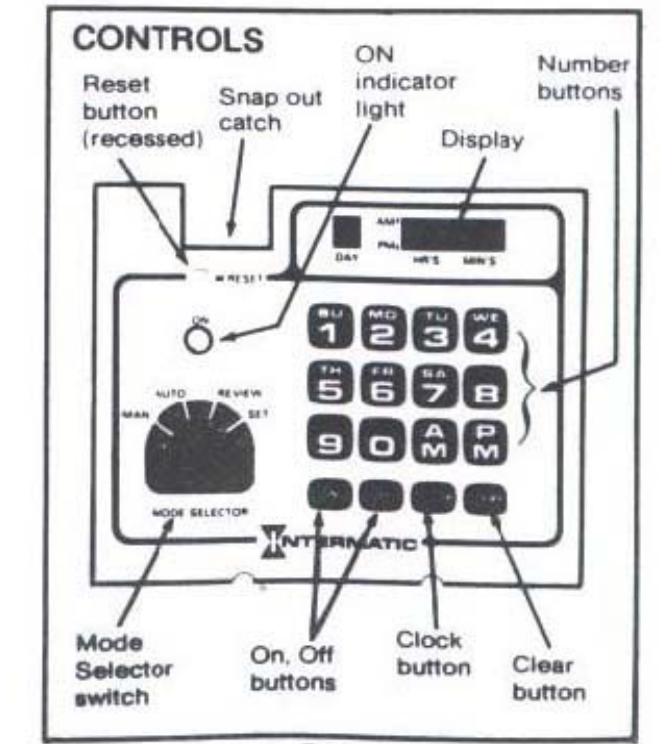
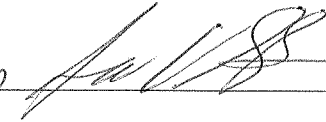

Figure 4 Electronic Seven-Day Timer

a EPA Document 40 CFR part 58, Appendix E

Sign-Off Sheet

I certify that I have read, understand and agree to follow the contents of Revision 1.1 of the "Hydrocarbons: Probe Installation, Sampler Installation, Removal and Electronics Repair Section I" QAP/SOP with an effective date of October 27, 2010. **Sign, date and return to the Ambient Monitoring Section Chief.**

ECB Technician: James H. Stroup  7-21-11

ECB Technician: _____

ECB Technician: _____

ECB Technician: _____